

Straight Thermocouples

acc. to EN 50 446 (DIN 43 733) for use in harsh industrial environments

In numerous branches of industry heat-treatment and combustion processes play a decisive role during production and in the quality of the final product. These applications have one thing in common:

Due to the high temperatures thermocouples are almost always used. Besides the non-precious-metal containing ones, mainly types E, J or L, K and N, platinum thermocouples types S, R or B are increasingly being used.

These must be protected against contaminating, corrosive and/or abrasive ambient influences. Various designs with different protection tube materials are available for these applications.

1) Ordering Code:

Example: TE-AMK-15x2-1.4762/K610-2K-1.38-2000

Connection head forms **A** or **B**
 Outer protection tube **M**etal or **K**eramik (Ceramic)
 Inner protection tube **K**eramik (Ceramic)
 (no letter = no inner protection tube)
 Coatings of outer protection tube on request

Diameter x wall thickness
 of outer protection tube (standard)
 15 x 2 mm, 22 x 2 mm, 24 x 3 mm (metal)
 10 x 1.5(2.0) mm, 15 x 2(2.5) mm, 24 x 2.5 mm,
 24 x 3 mm, 26 x 4 mm (ceramic)
 Other diameters on request

Material of outer protection tube acc. to table 2.2
 1.0305; 1.4749; 1.4762; 1.4841; 1.4876
 K 530 (C 530); K 610 (C 610); K 710 (C 799)
 Other materials on request

Material of inner protection tube acc. to table 2.3
 Porcelain K 530 (C 530)
 Aluminium - oxide K 610 (C 610)
 Aluminium - oxide K 710 (C 799)
 Other materials on request

Number of thermocouples and identification letter
 acc. to EN 60 584 (DIN 43 710), see table 2.4
 E, J (L), K, N as well as S, R and B
 Other types on request

Thermo wire diameter in mm
 1.0; 1.38; 2.5; 3.0 types E, J (L), K, N
 0.5; 0.35 types S, R and B

Nominal length l in mm (standard) acc. to table 2.1
 Other lengths on request

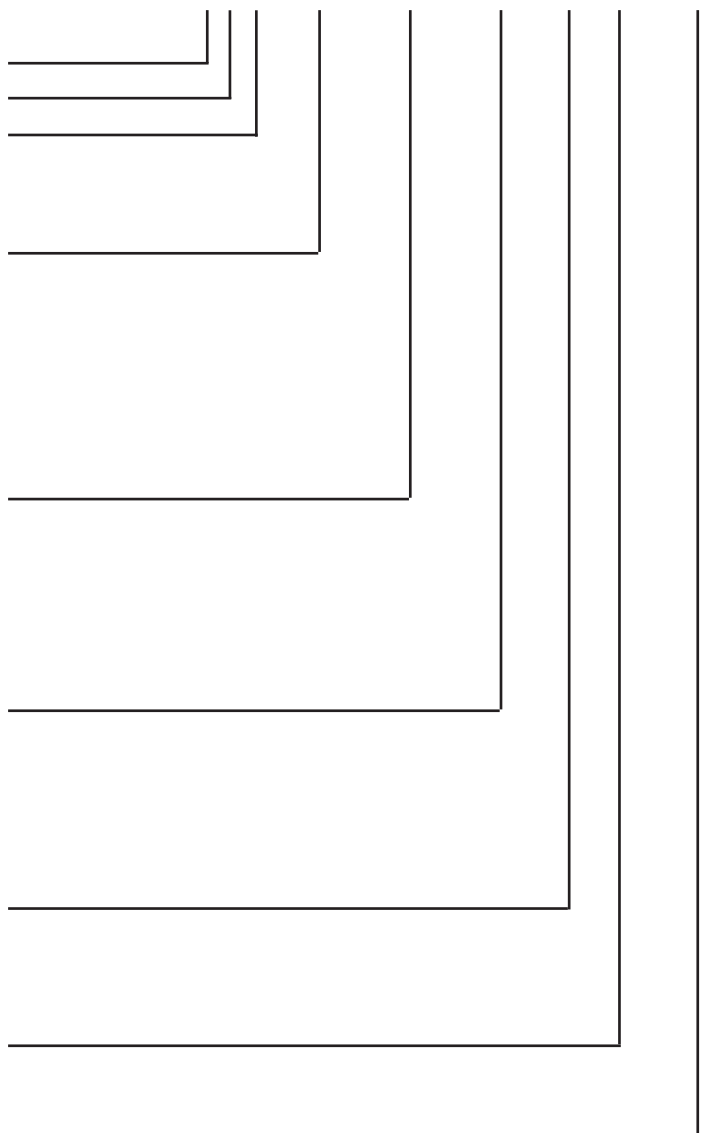

2) Straight Thermocouples with Metal Protection Tube

Model AM

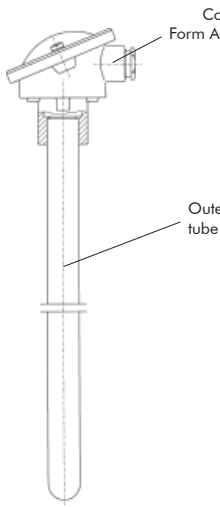

Model BM

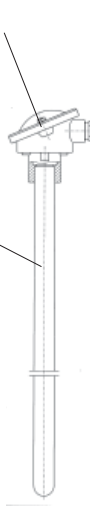

Model AMK

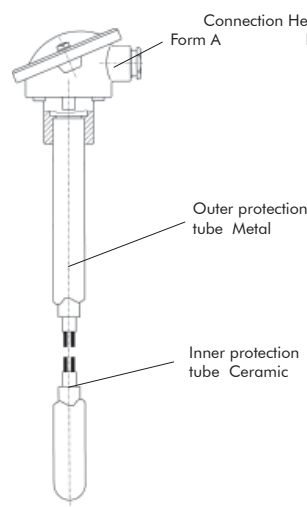

Model BMK

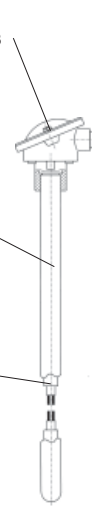

Short symbol for straight thermocouples			AM	AMK	BM	BMK				
Connection Head acc. to DIN EN 50 446			Form A			Form B				
Prot. Tube $d_1 \times s^1)$			Metal Protection Tube			22 x 2		15 x 2		
			24 x 3 (upon request)			-				
			26 x 4 (upon request)			-				
Ceramic Inner Prot. Tube			C 610	-	15 x 2	-	-	10 x 1,5		
			C 710	-	15 x 2,5	-	-	10 x 2		
1 TC=1 Thermocouple 2 TC=2 Thermocouple	Identification Letter	Diameter								
	E, J (L), K, N *)	3.0	1 TC	2 TC	1 TC	-	-	-	-	-
	E, J (L), K, N *)	2.5	1 TC	2 TC	1 TC	2 TC	-	-	-	-
	E, J (L), K, N *)	1.38	1 TC	2 TC	1 TC	2 TC	1 TC	2 TC	1 TC	2 TC
	E, J (L), K, N *)	1.0	1 TC	2 TC	1 TC	2 TC	1 TC	2 TC	1 TC	2 TC
Insulation tubes acc. to EN 50 113	*) Thermocouple(s) preferable form A or B acc. to EN 50 113									
	R, S, B **)	0.5; 0.35	-	-	1 TC	2 TC	-	-	1 TC	2 TC
	**) Thermocouple(s) preferable form C or D acc. to EN 50 113									
Nominal Length NL			-			355				
Remark: At nominal lengths of 2000 and longer while horizontal mounted an additional support is highly recommended, when mounting horizontally!			500			500				
			710			710		710		
			1000			1000		1000		
Model AM: Special lengths up to 6000 mm upon request.			1400			1400		-		
Model AMK: Special lengths up to 2500 mm upon request.			2000 ²⁾			-		-		

¹⁾ „s“ is the wall thickness of the protection tube.

²⁾ This nominal length with a noble-metal thermocouple is not recommended for mounting vertically.

2.1) Straight Thermocouples with Ceramic Protection Tube

Model AK

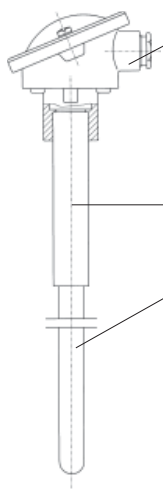

Model BK

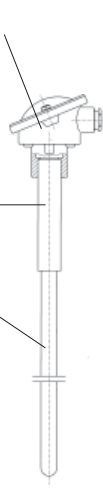

Model AKK

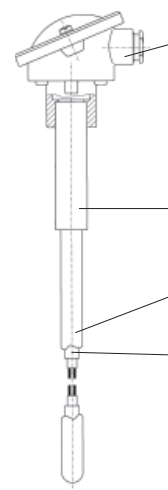

Model BKK

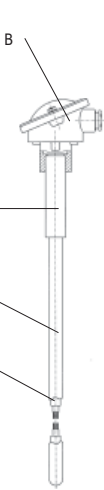

Short symbol for straight thermocouples		AK	AKK	BK	BKK					
Connection Head acc. to DIN EN 50 446		Form A		Form B						
	$d_2 \times s / l_2$	32x2/200	22x2/150	15x2/80 od. 22x2/80						
Prot. Tube $d_1 \times s$ 1)	Ceramic Protection Tube	C 530	26 x 4	-	-					
		C 610	24 x 2.5	15(16) x 2	15x2/10x1.5	15x2/10x1.5				
		C 710	24 x 3	15 x 2.5	15x2.5/10x2	15x2.5/10x2				
	Ceramic Inner Prot. Tube	C 610	15(16) x 2	10 x 1.5	-	-				
C 710		15 x 2.5	10 x 2	-	10x2/6x1					
1 TC=1 Thermocouple 2 TC=2 Thermocouple Thermocouple acc. to DIN EN 60 584-1 (Type L - DIN 43 710) Insulation tubes acc. to EN 50 113	Identification Letter	Diameter								
	E, J (L), K, N *)	3.0	1 TC	-	-	-	-	-	-	-
	E, J (L), K, N *)	2.5	1 TC	2 TC	1 TC	2TC ³⁾	1 TC	2TC ³⁾	-	-
	E, J (L), K, N *)	1.38	1 TC	2 TC	1 TC	2 TC	1 TC	2 TC	-	-
	E, J (L), K, N *)	1.0	1 TC	2 TC	1 TC	2 TC	1 TC	2 TC	-	-
*) Thermocouple(s) preferable form A or B acc. to EN 50 113										
	R, S, B **)	0.5; 0.35	-	-	1 TC	2TC	-	-	1 TC	2TC ³⁾
**) Thermocouple(s) preferable form C or D acc. to EN 50 113										
Nominal Length NL			-		355					
Remark: At nominal lengths of 2000 and longer while horizontal mounted an additional support is highly recommended, when mounting horizontally!			500		500					
Model AM: Special lengths up to 6000 mm upon request. Model AMK: Special lengths up to 2500 mm upon request.			710		710		710			
			1000		1000		1000			
			1400		1400		-			
			2000 ²⁾		-		-			

1) „s“ is the wall thickness of the protection tube.

2) This nominal length with a noble-metal thermocouple is not recommended for vertical mounting.

3) 2 thermocouples are not possible with ceramic outer or inner protection tube of 10 x 2 mm.

4) 2 thermocouples are possible only with a wire diameter 0.35 mm.

5) This model is only available with an outer diameter of 15 mm.

3) Identification and dimensions of the metal protection tubes

Form A
Prot. tube, round bottom

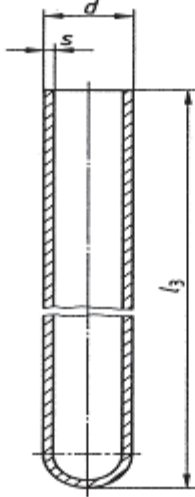

Form B
Extended prot. tube,
round bottom

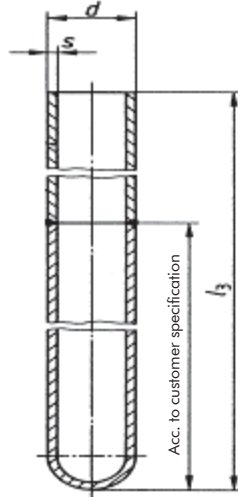

Form C
Protection tube,
weld-in bottom

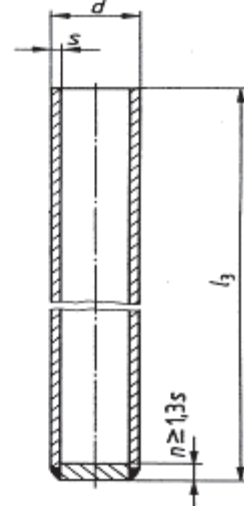

Example: Protection tube A22D x 1020

Identification of a metal protection tube form A with $d = 22$ mm diameter and $l_3 = 1020$ mm length, material number 1.4841 (DIN 17 442), nominating letter D acc. to table 3.2

Table 3.1 Dimensions and permitted deviations for metal protection tubes without bushing

Form	d +0.2/-0.1	s +/-0.1	For straight thermocouples with a nominal length l						
			250	355	500	710	1000	1400	2000
			Prot. tube length l_3 Permitted deviation +3.0/-0					Prot. tube length l_3 Perm. deviation +5.0/-0	
A / C	15	2	265	370	515	-	-	-	-
	22	2	-	-	520	730	1020	1420	2020
	24	3	-	-	520	730	1020	1420	2020
B	22	2	-	-	-	-	1020	1420	2020

Protection tubes form A and C are technically equivalent.
Coatings on metal protection tubes are to be agreed between vendor and user. Please note differing diameters.

Ident. letter	Short name	Material No.
BF	St 35.8	1.0305
BL	C 22.8	1.0460
J	X6CrNiMo17-12-2	1.4571
DU	X18CrNi28	1.4749
R	X10CrAl24	1.4762
D	X15CrNiSi2520	1.4841
B	Inconel 600	2.4816
Y	Incoloy 800	1.4876
CS	Kanthal Super/AF/APM ¹⁾	-

Ident. letter	Material acc. to DIN 40 685 Part 1 VDE 0335 Part 1
CX	C 530 / K530
CY	C 610 / K 610
CZ	C 710 / K 710
RSiC ¹⁾	Silicon carbide, recrystallized ²⁾
SiSiC ¹⁾	Silicon carbide, react. bonded ²⁾

¹⁾ Differing diameter
²⁾ Please ask for detailed specifications
³⁾ Standard withdrawn 07/97
⁴⁾ Draft IEC 60 584©65B/737/CD

Ident. letter	Thermocouple DIN EN 60 584-1
E	NiCr-CuNi
J	Fe-CuNi
K	NiCr-Ni
N	NiCrSi-NiSi
S	Pt10%Rh-Pt
R	Pt13%Rh-Pt
B	Pt30%Rh-Pt6%Rh
L	Fe-CuNi (DIN 43 710) ³⁾
D (AO)	W3%Re-W25%Re
C ⁴⁾ (AE)	W5%Re-W26%Re
A ⁴⁾	W5%Re-W20%Re

4) Specifications and Dimensions of Ceramic Protection Tubes and Fastening Rings

Protection Tube A15CZ - 1030

Description of a ceramic protection tube with $d_1 = 15$ mm diam. and length $l = 1030$ mm, made from ceramic material C 799 (K710). See table to the right for fastening rings for inner protection tubes.

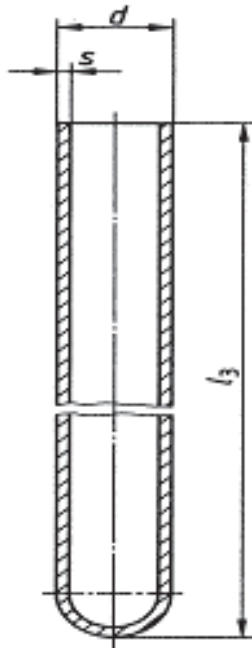

Fastening Ring (HR) - 24

Description of a fastening ring ("HR") for a ceramic protection tube with a diam. of $d_1 = 24$ mm. The fastening ring is applied by pressing in the bulges. Please make sure that it fits tightly around the protection tube, as - in case of vertical mounting of the thermocouple.

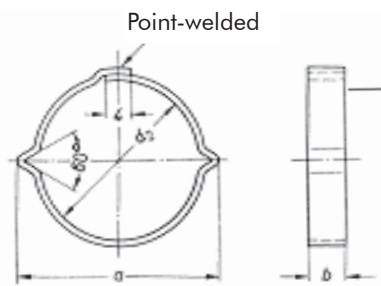

Table 4.2

For prot. tube d_1	$d_2 +0,5 / +1$
6	6
10	10
15	15
16	16

Table 4.1 Dimensions and permitted deviations for a ceramic protection tube without pipe screw joint

d_1 1)	s min.	For straight thermocouples model AK, AKK, BK and BKK						Protection tube material	Temperature shock resistance	Tightness 3)	Permitted permanent temperature in °C 2)
		355	500	710	1000	1400	2000				
		Protection tube length l_3				Perm. deviation +5 /-0					
		Permitted deviation +3 /-0									
10	1.5	375	520	730	1020	-	-	C 610 (K 610)	Medium to good	Gas-tight	1500
15/16	2	-	530	740	1030	1430	-				
24	2.5	-	530	740	1030	1430	2030				
10	2	375	530	740	1030	-	-	C 710 (K 710)	Medium	Gas-tight	1600
15/16	2.5	-	530	740	1030	1430	-				
24	3	-	530	740	1030	1430	2030				
26	4	-	-	740	1030	1430	2030	C 530	Very good	Porous	1500
20 5)	5	-	530	740	1030	1430	-	SiSiC 4)	Very good	Gas-tight	1350
22 6)	5	-	530	740	1030	1430	2030				
25 6)	5	-	530	740	1030	1430	2030				
20 6)	3.5	-	530	740	1030	1430	-	RSiC 4)	Good	Porous	1600
22 6)	3.5	-	530	740	1030	1430	2030				
25 7)	3.5	-	530	740	1030	-	2030				

1) d_1 must be maintained over a length of 20 mm with a permitted deviation of +/- 0.5 mm.

2) Noble-metal thermocouples are predominantly used for measuring temperatures above 1000 °C. When installed in protection tubes and insulation rods made from the above indicated ceramic insulation materials, it has to be taken into account that in a reducing atmosphere the thermocouples may be affected. Of particular influence and reducing the admissible permanent temperature are silicon and heavy metals.

3) At temperatures above approx. 1000 °C gas-tightness can no longer be assumed.

4) When using SiC protection tubes type AK only non-precious-metal thermocouples should be installed. With type AKK the installation of an inner protection tube made of C 799 is strongly recommended when having noble-metal thermocouples.

5) Type AKK: inner protection tube 6 x 1

6) Type AKK: inner protection tube 10 x 2

7) Type AKK: inner protection tube 15 x 2.5

5) Flanges, Counter Flanges and Threaded Sleeves

Flanges in Al or GtW

Description:

e.g. flange - nominal size (22) - material (Al)

Material: Al = Aluminium; GtW = Malleable Iron

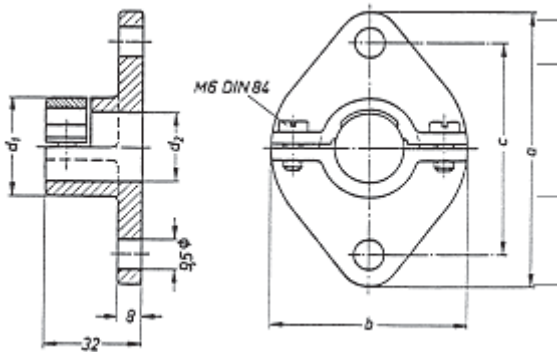

Installation Example with counter flange for welding



Tabelle 5.1

Support tube Prot. tube (Nominal size) d_2	Flange dimensions		
	A	B	C
15	75	50	55
22	90	65	70
24			
26			
32			

Threaded Sleeves in Steel, galvanically zinc-plated

Operating temperature max. 400 °C. Asbestos-free seal fibre material

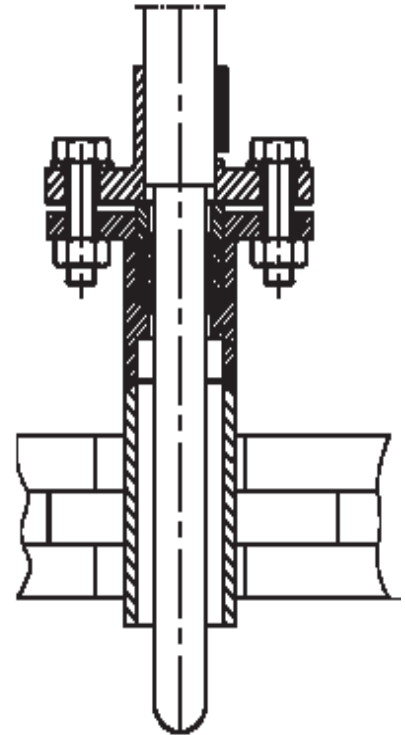
Description: e.g. Threaded sleeve (GM) - thread (G1) - nominal size (22)

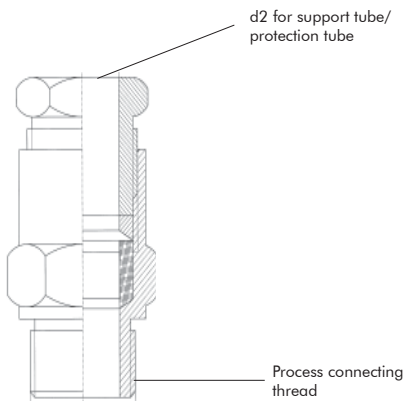

Table 5.2 Dimensions

Support tube / Protection tube diameter	d_2	Process connection thread	Process connection thread	Process connection thread
10	10.5	<i>M 20x1.5</i>	G 3/4"	1/2" NPT
15	15.5	<i>M 27</i>	G 3/4" / G 1"	3/4" NPT
22	22.5	<i>M 36</i>	G 1"	1" NPT
24	24.5	<i>M 42</i>	G 1 1/4"	1 1/4" NPT
26	26.5	<i>M 42</i>	G 1 1/4"	1 1/4" NPT
32	32.5	<i>M 48</i>	G 1 1/4" / G 1 1/2"	1 1/4" / 1 1/2" NPT

Thread sizes in italics are available on request only

6) Color-Coding of Extension or Compensating Cables for Thermocouples acc. to IEC 60 584-3:2008 (DIN 43 722)

Material	Fe-CuNi	Fe-CuNi	NiCr-Ni	Cu-CuNi	NiCr-CuNi	NiCrSi-NiSi	Pt10Rh-Pt	Pt13Rh-Pt	Pt30Rh-Pt6Rh
Ident. Letter	L *	J	K	T	E	N	S	R	B
Color „+“ Pole	---	black	green	brown	lilac	pink	orange	orange	No color defined
	(red)	(---)	(red)	(red)	(---)	(---)	(red)	(red)	
Color „-“ Pole	---	white	white	white	white	white	white	white	
	(blue)	(---)	(green)	(brown)	(---)	(---)	(white)	(white)	
Color Sheath	---	black	green	brown	lilac	pink	orange	orange	No color defined
	(blue)	(---)	(green)	(brown)	(---)	(---)	(white)	(white)	

Identification letters acc. to DIN EN 60 584 (DIN 43 710)

* Type L acc. to DIN 43 710 (standard withdrawn 07/97)

Identification colors in brackets acc. to withdrawn DIN 43 714

7) Thermal-EMF Tables acc. to IEC 60 584-1

Reference temperature 0 °C

) Type L acc. to DIN 43 710 (Standard withdrawn)

Type C (AE) and Type A acc. to draft IEC 60 584©65B/737/CD

Temp. in °C	Type L ¹⁾ in µV	Type J in µV	Type K in µV	Type T in µV	Type E in µV	Type N in µV	Type S in µV	Type R in µV	Type B in µV	Type C in µV	Type A in µV
-200	-8150	-7890	-5891	-5603	-8825	-3990					
-100	-4750	-4633	-3554	-3379	-5237	-2407					
0	0	0	0	0	0	0	0	0	0	0	1
100	5370	5269	4096	4279	6319	2774	646	647	33	1451	1337
200	10950	10779	8138	9288	13421	5913	1441	1469	178	3090	2872
300	16560	16327	12209	14862	21036	9341	2323	2401	431	4865	4513
400	22160	21848	16397	20872	28946	12974	3259	3408	787	6732	6204
500	27850	27393	20644		37005	16748	4233	4471	1242	8657	7908
600	33670	33102	24905		45093	20613	5239	5583	1792	10609	9606
700	39720	39132	29129		53112	24527	6275	6743	2431	12559	11284
800	46220	45494	33275		61017	28455	7345	7950	3154	14494	12934
900	53140	51877	37326		68787	32371	8449	9205	3957	16398	14550
1000		57953	41276		76373	36256	9587	10506	4834	18260	16128
1100		63792	45119			40087	10757	11850	5780	20071	17662
1200		69553	48838			43846	11951	13228	6786	21825	19150
1300			52410			47513	13159	14629	7848	23520	20589
1400							14373	16040	8956	25155	21976
1500							15582	17451	10099	26729	23311
1600							16777	18849	11263	28243	24593
1700							17947	20222	12433	29696	25822
1800									13591	31087	26998
1900										32413	28120
2000										33669	29186

8) Permitted Deviations for Thermocouples acc. to IEC 60 584-2

Permitted deviation	Class 1	Class 2	Class 3
Permitted deviation +/-]* Measuring range type T	0.5 °C or 0.004 x (t) °C -40 ... +350 °C	1.0 °C or 0.0075 x (t) °C -40 ... +400 °C	1.0 °C or 0.015 x (t) °C -200 ... +40 °C
Permitted deviation +/-]* Measuring range type J Measuring range types K & N Measuring range type E	1.5 °C or 0.004 x (t) °C -40 ... +750 °C -40 ... +1000 °C -40 ... +800 °C	2.5 °C or 0.0075 x (t) °C -40 ... +750 °C -40 ... +1200 °C -40 ... +900 °C	2.5 °C or 0.015 x (t) °C --- -200 ... +40 °C -200 ... +40 °C
Permitted deviation +/-]* Measuring range types S & R Measuring range type B	1.0 °C or (1+(t-1100) x 0.003) °C 0 ... +1600 °C ----	1.5 °C or 0.0025 x (t) °C 0 ... 1600 °C 600 ... 1700]**	4.0 °C or 0.005 x (t) °C ---- 600 ... 1700]**

] * The higher value applies

(t) = Numeric value of temperature in °C without algebraic signs

] ** Recommended operating temperature range

The normally available materials for thermocouples maintain the permitted deviations acc. to a.m. table at temperatures above -40 °C. These materials do not necessarily maintain the permitted deviation of class 3 at temperatures below -40 °C. When thermocouples type E, J, K and N are required which maintain permitted deviations of class 3 as well as class 1 or 2 the customer has to specify this expressly because a special selection of available material has to be done.

9) Remarks regarding the Selection of Protection Tube Materials

Material	Max. operating temp. in °C	Characteristics/Application	Remarks
Titanium	600	Hardening and quenching bathes	Highly oxidizing at air
Pure iron 1.1003	900	Saltpeter-, Chloride-, Cyanide-containing hardening bathes	Highly oxidizing at air
Steel, enameled	600	Molten zinc	Shock-sensitive
1.10305	900	Tempering furnaces, saltpeter bathes up to 500 °C, molten lead, babbitt metal and zinc	In case of lead oxide with hard chromium coating
1.4571	800	Good chemical resistivity	Gas-tight inner tube recommended (form AMK/BMK)
1.4762	1200	High resistivity against sulfur-containing atmospheres, medium resistivity against carburisation	Gas-tight inner tube recommended (form AMK/BMK)
1.4749	1100	Molten lead and tin, anneal and tempering furnaces with sulfur- and carbon-containing gases	Gas-tight inner tube recommended (form AMK/BMK)
1.4772	1250	Molten copper and brass	Gas-tight inner tube recommended (form AMK/BMK)
1.4821	1350	Saltpetre-, chloride-, cyanide-containing salt bathes	Gas-tight inner tube recommended (form AMK/BMK)
1.4841	1200	Cyanogen bathes up to 950 °C, molten lead up to 700 °C, furnaces with nitrogenous, low-oxygen gases	Gas-tight inner tube recommended (form AMK/BMK)
Cast iron GG 22	700	Molten babbitt metal, lead, aluminium and zinc	Brittle, shock-sensitive
GG with ceramic coating	800	Molten aluminium and zinc	Shock-sensitive
Chromium-aluminium oxide Cr Al ₂ O ₃ 60/40	1200	Gas-tight, oxidation-resistant, temperature-shock-resistant; melting plants for copper, tin, zinc, magnesium and lead; cement furnaces; resistant against SO ₂ -, SO ₃ -gas and H ₂ SO ₄ -acid	Not for molten aluminium, glass and salt bathes
Molybdenum-disilicide MoSi ₂	1700	Abbrasion-resistant, shock-resistant, highly temperature-shock-resistant, surface glazed, chemical resistant, waste incineration, fluidized bed combustion	Brittle at low temperatures, above ~ 1400 °C viscid
Molybdenum Zirconium Oxide MoZrO 60/40	1700	Temperature shock-resistant, shock-resistant, molten cast iron, copper and zinc, clinker, BaCl ₂ -quenching bathes	Oxidizes in air at temperatures > 500 °C
C 530	1500	All kinds of gases with form AKK, temperature shock-resistant	Gas-tight inner tube
C 610	1600	All kinds of gases with form AKK, less temperature shock-resistant	Gas-tight inner tube
C 799	1600	All kinds of gases with contact with hydrofluoric acid, metal oxide, alkaline gases, molten glass	Molten glass with platinum thimble
Silicon carbide RSiC recrystallized	1600	Porous, highly mechanically-resistant, high thermal conductivity, suitable under inert gas or vacuum up to 2000 °C	Not for molten Al, Cu, Ni, Fe, resistant against strong acids and bases
Silicon carbide SiSiC reaction-bonded	1350	Gas-tight, highly mechanically-resistant, highly temperature shock-resistant, high thermal conductivity, 8 - 12 % free silicon	High resistance against oxidation, resistant against strong acids and bases
Silicon Nitride Si ₃ N ₄	1000	Temperature shock-resistant, no wetting in molten aluminium and brass	Shock-sensitive
Silicon Nitride Aluminium Oxide Si ₃ N ₄ + Al ₂ O ₃	1300	Moderate temperature shock-resistant, molten tin, lead, zinc, cadmium and aluminium	Not for molten Al, Cu, Ni, Fe, highly temperature-shock-resistant
Graphite	1250	Oxygen-free molten copper, brass and aluminium	Highly oxidizing at air
Aluminiumtitanat Al ₂ TiO ₃	1000	Gas-tight, molten aluminium	Shock-sensitive
Sapphire	2000	Mono-crystalline aluminium-oxide, gas-tight, transparent, semiconductor industry, waste incineration, extreme high price	Shock-sensitive, moderate temperature-shock-resistant

The a.m. table does not claim to be complete and comprehensive. All data given in the a.m. table are typical but do not constitute binding and/or guaranteed characteristics. Any data needs to be verified in detail by the customer in relation to the specific application.

We reserve the right to change any specification without prior notice in line with our policy of continuous technical improvement.

RÖSSEL-Messtechnik GmbH

Lohstraße 2
59368 Werne/GERMANY
Fon: +49 2389 409-0
Fax: +49 2389 409-80
Mail: info@roesselwerne.de
Web: www.roesselwerne.de

RÖSSEL-Messtechnik GmbH

Spenerstraße 1
01309 Dresden/GERMANY
Fon: +49 351 31225-0
Fax: +49 351 31225-25
Mail: info@roesseldresden.de
Web: www.roesseldresden.de

RÖSSEL

Eikenlaan 253d
2404BP Alphen a/d Rijn
THE NETHERLAND
Fon: +31 172 493141
Fax: +31 172 495043
Mail: info@roessel.nl/Web: www.roessel.nl