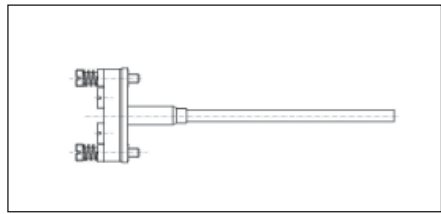
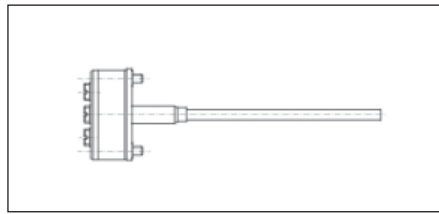
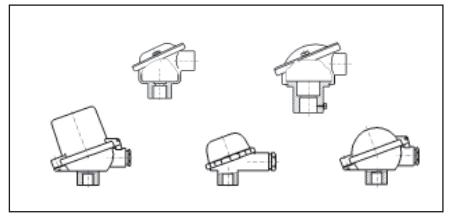
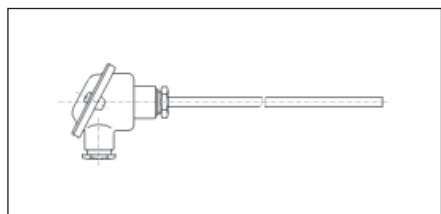
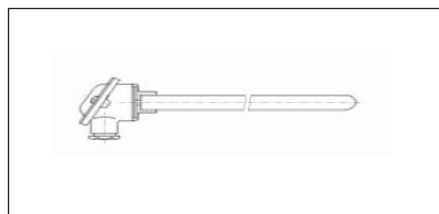
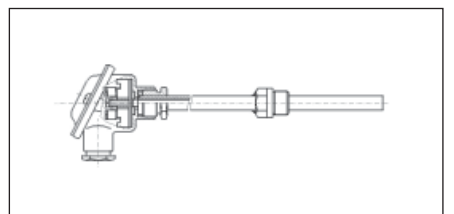
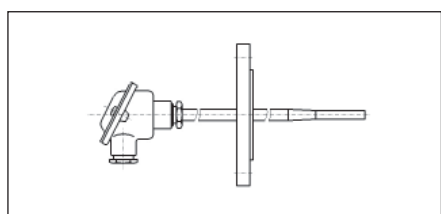
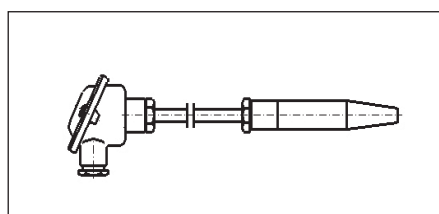
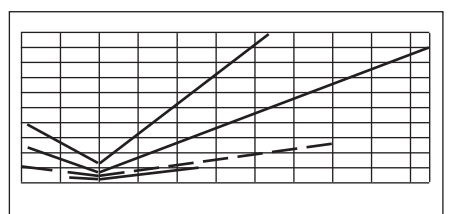

Metal-Protected Measuring Inserts

Thermocouples and Resistance Thermometers DIN 43 735

The following table shows in comparison the different types of measuring inserts. They are designed based on the presently valid version of DIN 43 735.

Measuring Insert design examples Page 2	Measuring Insert ordering code Page 3	Connection Head form A and B acc. to EN 50 446 Page 4
		
Measuring Insert without protection tube Page 5	Measuring Insert with protection tube form 1 Page 6	Measuring Insert with protection tube form 2G / 2F Page 7
		
Measuring Insert with protection tube form 3G / 3F Page 8	Measuring Insert with protection tube form 4 / 4F Page 9	Technical Data Page 10
		

The suitable protection tubes are indicated with their lengths. They are available in all forms acc. to DIN 43 772. Please refer to our Product Information 175 "Protection Tubes".

Further one-side closed protection tubes made of ceramic or metallic materials can be found in Product Information 172 "Straight Thermocouples".

Suitable accessories, like e.g. stop flanges, threaded sleeves, compression fittings, connection cables etc. are partially available from stock.

Standard connection heads made of aluminium or plastic are also available as well as those with enlarged cap for the mounting of up to two transmitters.

Our range of temperature transmitters can be found in Product Information "TMU".

For further informations please visit our websites shown below.

1) Measuring inserts and design examples of the measuring tip

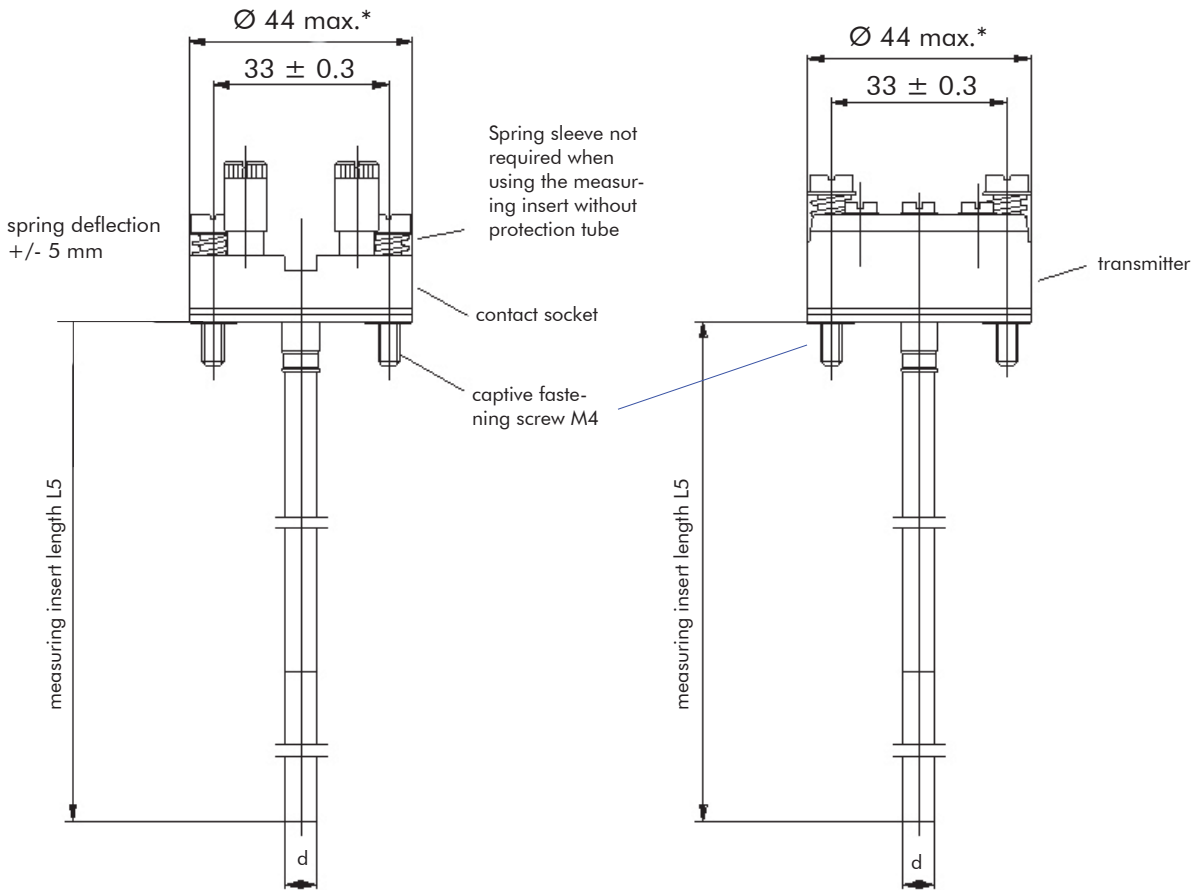

* Only when using connection head form B acc. to item 4.1 page 4

Thermocouple

Resistance Thermometer

Design I
insulated

Design G
grounded

Design I
insulated

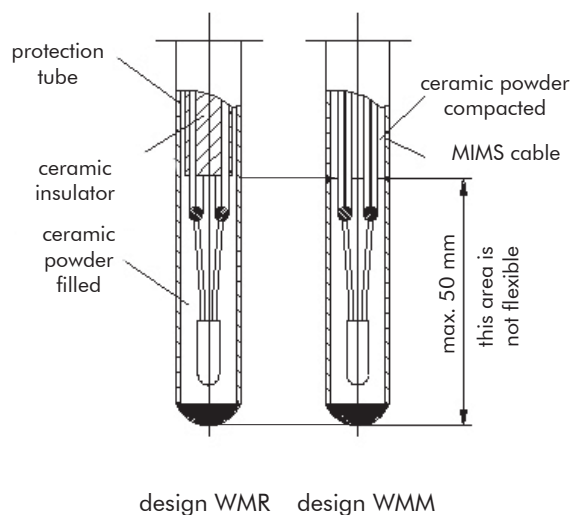
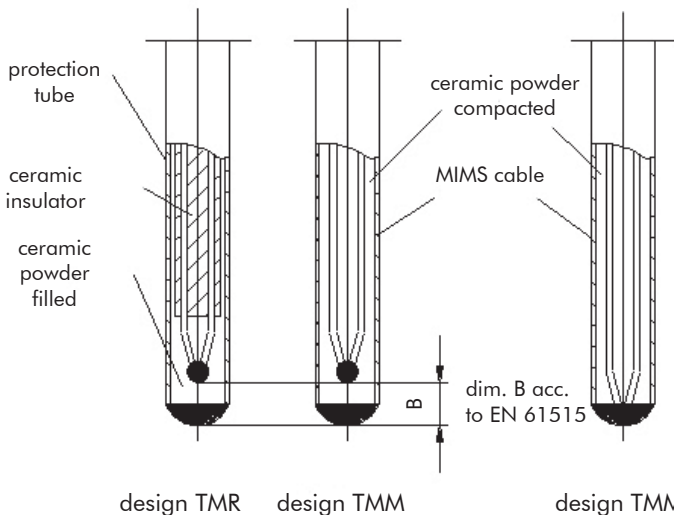

2) Ordering code for measuring inserts

Example resistance thermometer: WMR-610-1-Pt-AA-315-F-4-0-250-1.4571

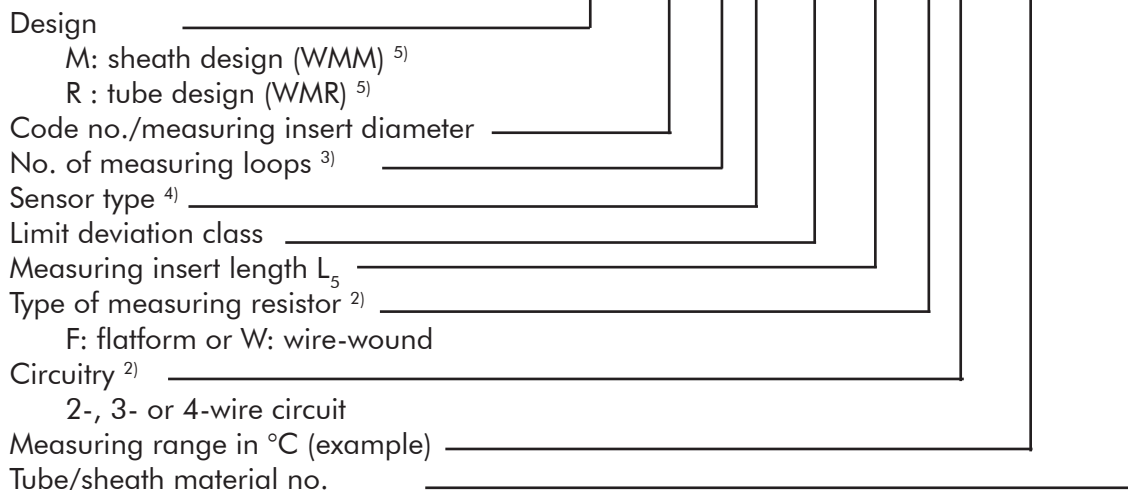

Example thermocouple: TMM-2-KB-6.0-315-1-I-0-850-2.4816

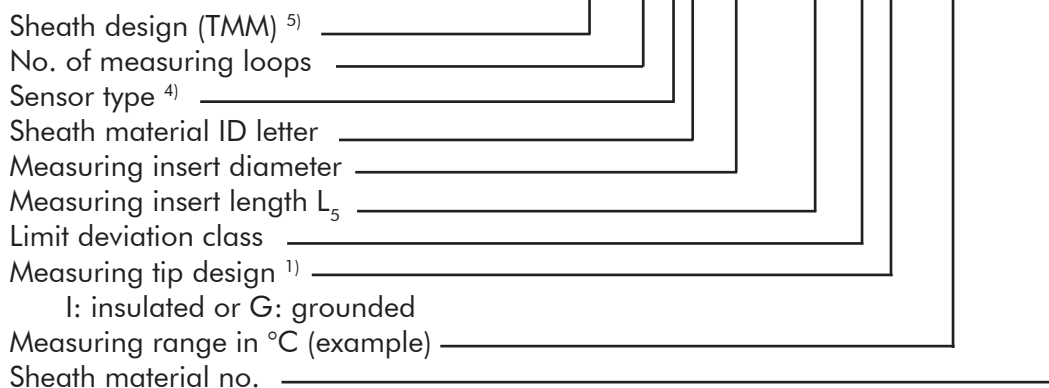

- 1) Applies only to thermocouples
- 2) Applies only to resistance thermometers
- 3) For measuring inserts with measuring resistors double resp. triple measuring resistors can be used instead of two or three measuring resistors
- 4) Thermocouples acc. to DIN EN 60 584, resistance thermometers acc. to DIN EN 60 751
- 5) **T** thermocouple / **W** resistance thermometer **M** measuring insert **M** sheath design (TMM/WMM)
W resistance thermometer **M** measuring insert **R** tube design (WMR)

The code number refers to the diameter of the tube/sheath. Code 600 defines the tolerance range as + 0 / -0.1 mm, code 610/810 as ± 0.1 mm. The tolerance ranges for the sheath design are nominal diameters d ± 0.01 * d.

The measuring length L₅ shown in the following tables is valid only when using a connection head form B acc. to EN 60 446. If a connection head form A is used, the given measuring insert lengths have to be increased by 10 mm.

The WMM/WMR duplex design with 4-wire circuit is available with the diameters 6.0/8.0 mm (WMM) resp. ID code 610/810 (WMR). This design can only be supplied for a connection head with enlarged connection space (BKD-SP/ BKD-RP resp. BKD-SPH/RPH).

ATEX designs with this circuitry are available only with 8.0 mm dia. (WMM) resp. ID code 810.

In addition to the mentioned standard measuring inserts with continuous diameters, reinforced (e.g. 5.0 to 6.0 mm) resp. reduced (e.g. 6.0 to 3.0 mm) designs are available on request.

3) Materials and identification letters for protection tubes and thermocouples

ID letter(s)	Short description	Material no.
BF	St 35.8	1.0305
BL	C 22.8	1.0460
J	X 6 CrNiMoTi 17-12-2	1.4571
DU	X 18 CrNi 28	1.4749
R	X 10 CrAl 24	1.4762
D	X 15 CrNiSi 25-20	1.4841
E	X 6 CrNiTi 18-10	1.4541
B	INCONEL 600	2.4816
Y	INCOLOY 800 ¹⁾	1.4876
CS	Kanthal Super/AF/APM ¹⁾	----
SAH	Pt10%Rh	----
N	Tantalum	----
O	Molybdenum	----

ID letters	Material acc. to DIN 40 685-1/ VDE 0335-1
CX	C 530 (K 530)
CY	C 610 (K 610)
CZ	C 710 (K 710)
RSiC	silicon-carbide, re-crystallized ¹⁾
SiSiC	silicon-carbide, react.-bonded ¹⁾

¹⁾ Different diameters
Please ask for exact specifications

ID letter(s)	Thermocouple DIN EN 60584-1
E	NiCr - CuNi
J	Fe - CuNi
K	NiCr - Ni
N	NiCrSi - NiSi
S	Pt10%Rh - Pt
R	Pt13%Rh - Pt
B	Pt30%Rh - Pt6%Rh
D(AO)	W3%Re - W25%Re
C(AE)	W5%Re - W26%Re
L	Fe - CuNi ²⁾

²⁾ standard withdrawn

4) Connection heads of aluminium and plastic

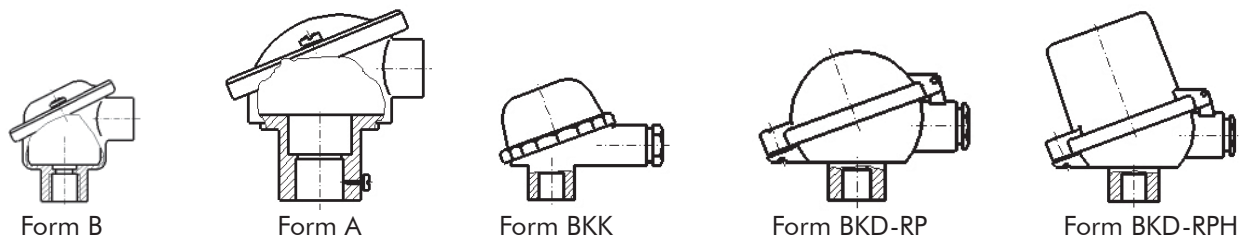

The connection heads with elevated cap are suitable for mounting one or two transmitters (forms BKD-SPH resp. BKD-RPH). Available are also plastic heads with screw cap, form BKK and with flap cap, form BKK-RPH. The standard cable screw-joints at all connection heads are M 20 x 1.5 (PG 16). The standard protection classification of the heads is IP 43. Other protection classifications (e.g. IP 54/65/66) as well as heads of other materials are available on request.

4.1) Connection heads form A and B of aluminium acc. to EN 50 446

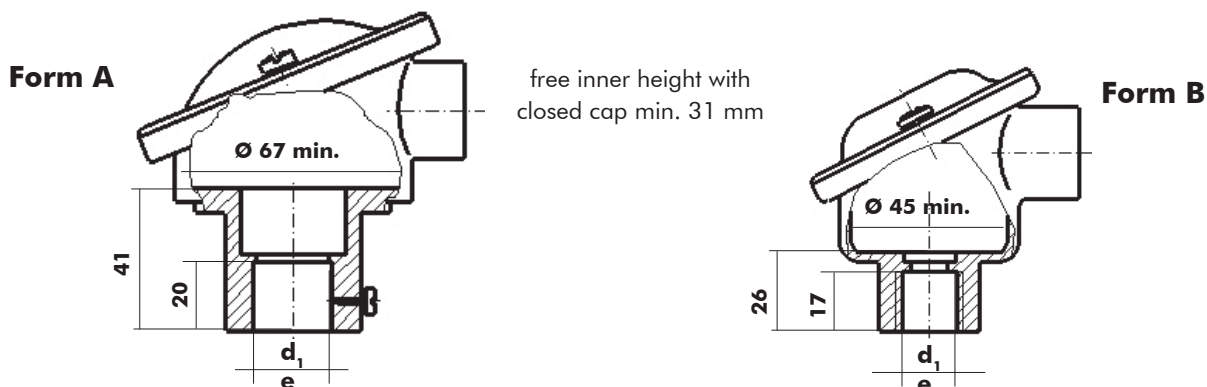

Table 4 Connection head dimensions

Form	Nominal dia. d1	Suitable for mounting of	Thread e	Suitable for mounting of
A	22.8	extension or protection tubes form 1 DIN 43 772 with 22 mm nominal dia.	M 24 x 1.5	extension tubes with head-mounted screw-joint
	24.8 / 26.8 / 32.8	extension or protection tubes with 24 mm / 26 mm / 32 mm nominal dia.	G1/2B; G3/4 B 1/2" NPT; 3/4" NPT	protection tubes with cyl. screw-joint protection tubes with con. screw-joint
B	15.8 / 22.8	extension or protection tubes form 1 DIN 43 772 with 15 resp. 22 mm nominal dia.	M 24 x 1.5 G 1/2 B	prot. tubes w. head-mounted screw-joint prot. tubes w. cyl. screw-in thread

5) Thermocouple and resistance thermometer without additional protection tube

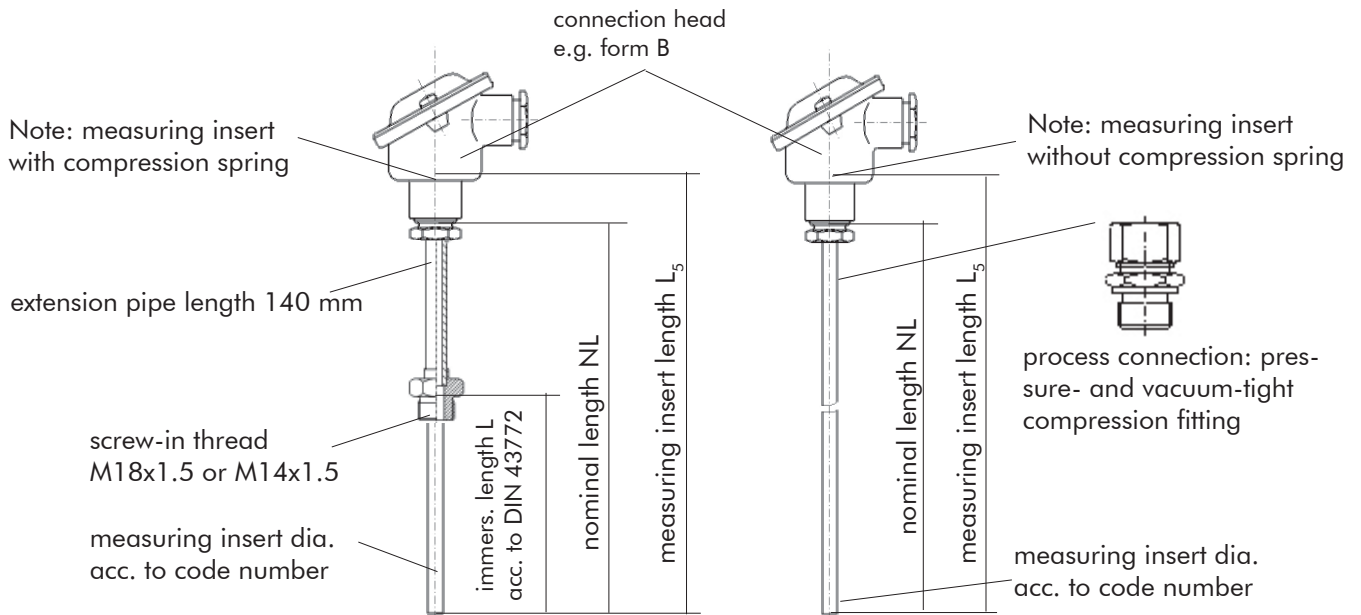

Fig. 5.1 – Thermocouple and resistance thermometer without additional protection tube

Note: The upper right hand illustration shows a design with head-mounted screw-joint. This reduces the available immersion depth to nominal length minus 10 mm (NL-10 mm).

In the following table 5 those lengths are given, which also fit the protection tubes as per DIN 43 772. Different lengths and diameters are available on request depending on the application.

Table 5 Measuring insert length to nominal length

Nominal length NL in mm	Measuring insert length L_5 in mm			Nominal length in mm for prot. tube length L in mm form 4 (form D) DIN 43 772 (DIN 43 763) N = M18x1.8/M14x1.5
	Code number (dia. in mm)			
	3.0	6.0 resp. 610	8.0 resp. 810	
250	275	275	---	---
260	285	285	---	110
290	315	315	---	140
320	345	345	---	170
350	375	375	---	200
380	405	405	---	---
410	435	435	---	260
500	525	525	525	---
530	555	555	555	---
610	585	585	-	410
630	655	655	655	N = extension pipe thread of form 4 (form D) protection tubes. Thread M14x1.5 for protection tubes with F1 = 18 mm and 3.5 mm bore for measuring inserts code number 3.0. Thread M18x1.5 for protection tubes with F1 = 24 mm and 7 mm bore for measuring inserts code number 6.0.
710	735	735	735	
800	---	825	825	
1 000	---	1 025	1 025	
1 250	---	1 275	1 275	
1 400	---	1 425	1 425	
1 600	---	1 625	1 625	
1 800	---	1 825	1 825	
2 000	---	2 025	2 025	

Code number 3.0 as well as measuring insert lengths ≥ 1000 are available only in MIMS design

6) Thermocouple and resistance thermometer with protection tube form 1 acc. to DIN 43 772, straight immersion thermocouple and resistance thermometer

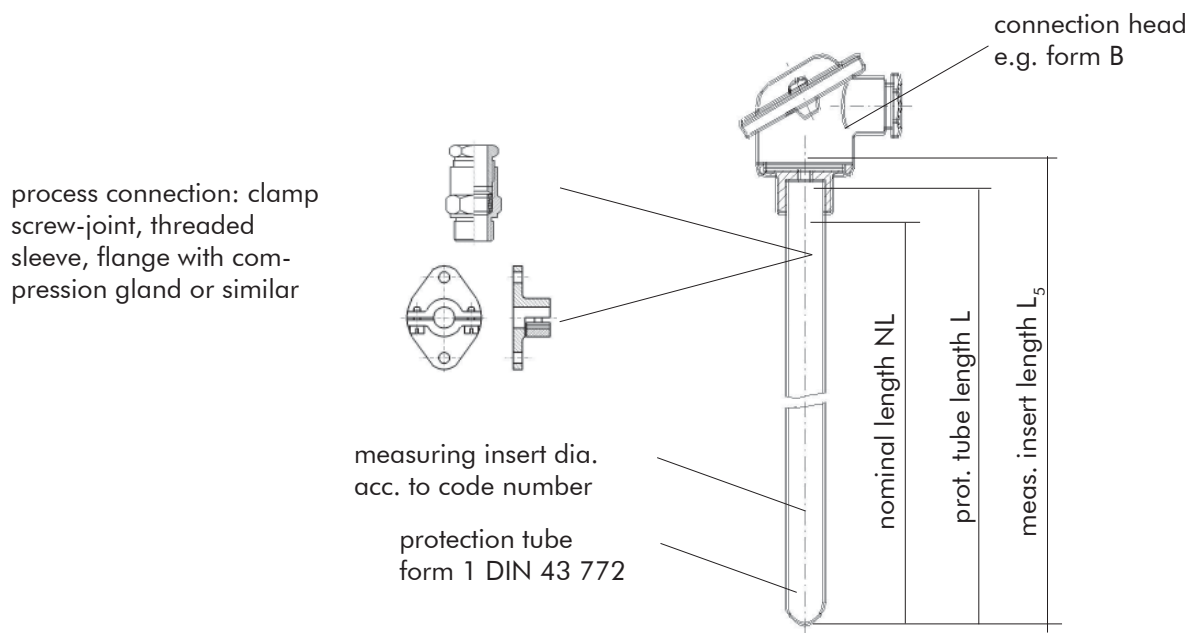

Fig. 6.1 – Thermocouple and resistance thermometer with protection tube form 1.

The design of the protection tube corresponds to DIN 43 772. The straight thermocouples are available in all designs as per our Product Information 172 as well as in numerous special designs on request.

Table 6 Measuring insert length to protection tube length form 1 acc. to DIN 43 772

Nominal length NL in mm	Prot. tube length L in mm for conn. head form B / A	Meas. insert length L_5 in mm for conn. head form B	Meas. insert length L_5 in mm for conn. head form A
500	517 / 520	525	535
710	727 / 730	735	745
1000	1017 / 1020	1025	1035
1400	1417 / 1420	1425	1435
2000	2017 / 2020	2025	2035

Different measuring insert lengths and diameters are available on request, depending on the design of the protection tube.

In addition to the simple, duplex and triplex designs profile thermocouples with different sensor lengths in a common protection tube are available.

7) Thermocouple and resistance thermometer with protection tube form 2G and 2F acc. to DIN 43 772, screw-in or flange TC and RTD

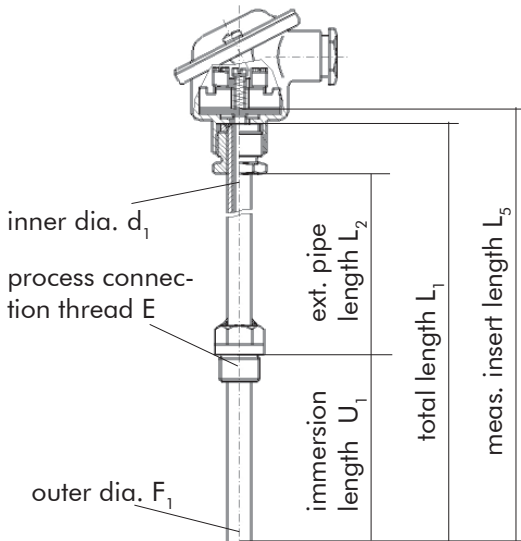

Fig. 5 – Thermocouple and resistance thermometer form 2G

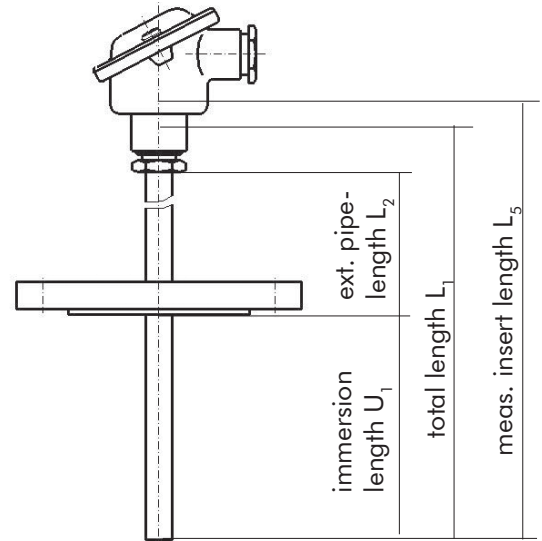

Fig. 6 – Thermocouple and resistance thermometer form 2F

Table 7 Insert length to protection tube length form 2G and 2F acc. to DIN 43 772

Form DIN 43 772 (DIN 43763)	Meas. insert length L_5 in mm for conn. head form B	Total length L_1 in mm	Immersion length U_1 in mm	Extension pipe L_2 in mm	Process connection thread E	Outer diameter F_1 in mm	Inner diameter d_1 in mm
2 G (B 9)	315 / Ø 6	305	160	120	G 1/2" B (M18 x 1.5)	9	7
	405 / Ø 6	395	250				
	555 / Ø 6	545	400				
2 G (B 11)	340 / Ø 8	330	160	145	G 1/2" B (M18 x 1.5)	11	9
	430 / Ø 8	420	250				
	580 / Ø 8	570	400				
2 G (B 12)	315 / Ø 6	305	160	120	G 1/2" B (M18 x 1.5)	12	7
	405 / Ø 6	395	250				
	555 / Ø 6	545	400				
2 G (C 11)	340 / Ø 6	330	160	145	G 1" B (M27 x 2)	11	7
	430 / Ø 6	420	250				
	580 / Ø 6	570	400				
2 G (C 12)	340 / Ø 6	330	160	145	G 1" B (M27 x 2)	12	7
	430 / Ø 6	420	250				
	580 / Ø 6	570	400				
2 G (C 14)	340 / Ø 8	330	160	145	G 1" B (M27 x 2)	14	9
	430 / Ø 8	420	250				
	580 / Ø 8	570	400				
2F	315 / Ø 6	305	225	55	Flange acc. to customer specifications	9	7
	405 / Ø 6	395	315				
	555 / Ø 6	545	465				
2F	315 / Ø 6 or Ø 8	305	225			11	7 or 9
	405 / Ø 6 or Ø 8	395	315				
	555 / Ø 6 or Ø 8	545	465				
2F	315 / Ø 6	305	225			12	7
	405 / Ø 6	395	315				
	555 / Ø 6	545	465				
2F	315 / Ø 8	305	225			14	9
	405 / Ø 8	395	315				
	555 / Ø 8	545	465				

Different measuring insert lengths and diameters are available on request, depending on the design of the protection tube. In addition to the simple, duplex and triplex designs profile thermocouples with different sensor lengths in a common protection tube are available.

8) Thermocouple and resistance thermometer with protection tube form 3G and 3F acc. to DIN 43 772, screw-in or flange thermocouple and resistance thermometer

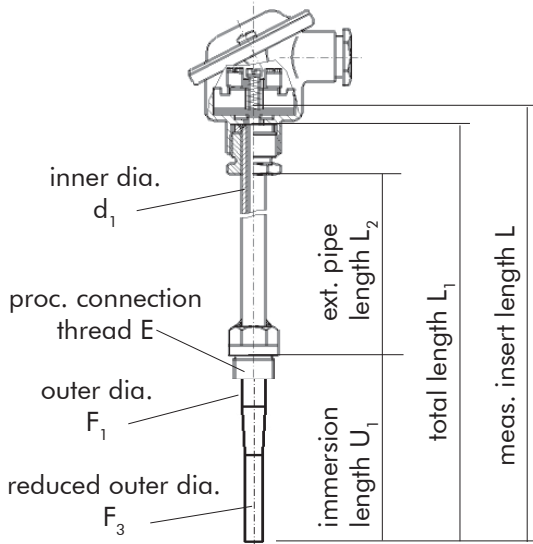

Fig. 8.1 – Thermocouple and resistance thermometer with protection tube form 3G

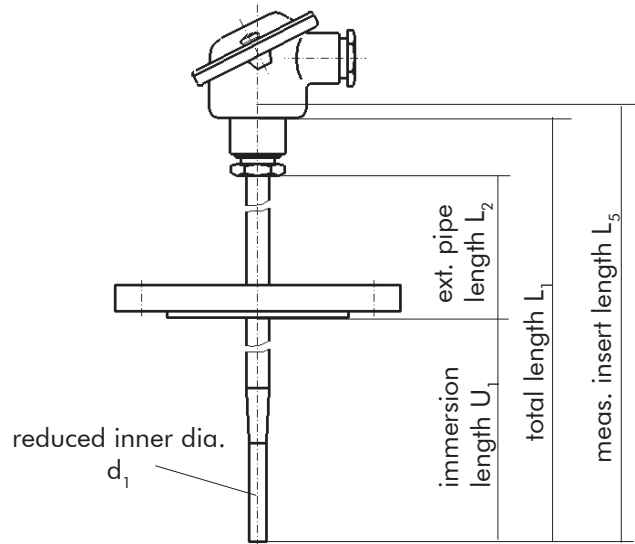

Fig. 8.2 – Thermocouple and resistance thermometer with protection tube form 3F

Table 8 Measuring insert length to protection tube length 3G and 3F acc. to DIN 43 772

Form DIN 43 772	For conn. head form B meas. insert L_5 in mm	Total length L_1 in mm	Immersion length U_1 in mm	Extension pipe length L_2 in mm	Process connection thread E	Outer dia- meter F_1 in mm	Reduced outer dia. F_3 in mm	Reduced inner dia. d_1 in mm		
3 G	315 / Ø 6	305	160	120	G ½" B (M22 x 1.5) or G 1" B (M27 x 2)	12 (d = 7)	9	6 +0.1/+0.05		
	375 / Ø 6	365	220							
	435 / Ø 6	425	280							
3 G	315 / Ø 8	305	160			55		14 (d = 9)	11	8 +0.1/+0.05
	375 / Ø 8	365	220							
	435 / Ø 8	425	280							
3 F	315 / Ø 6	305	225	55		12 (d = 7)	9	6 +0.1/+0.05		
	375 / Ø 6	365	285							
	435 / Ø 6	425	345							
3 F	315 / Ø 8	305	225			55		14 (d = 9)	11	8 +0.1/+0.05
	375 / Ø 8	365	285							
	435 / Ø 8	425	345							

Different measuring insert lengths and diameters are available on request, depending on the design of the protection tube.

In addition to the single, duplex and triplex designs profile thermocouples with different sensor lengths in a common protection tube are available.

9) Thermocouple and resistance thermometer with protection tube form 4 and 4F acc. to DIN 43 772, weld-in or flange thermocouple and resistance thermometer

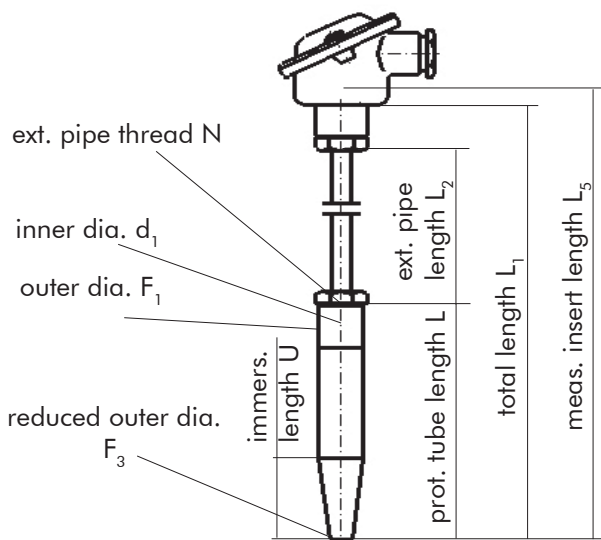

Fig. 9.1 – Thermocouple and resistance thermometer with protection tube form 4

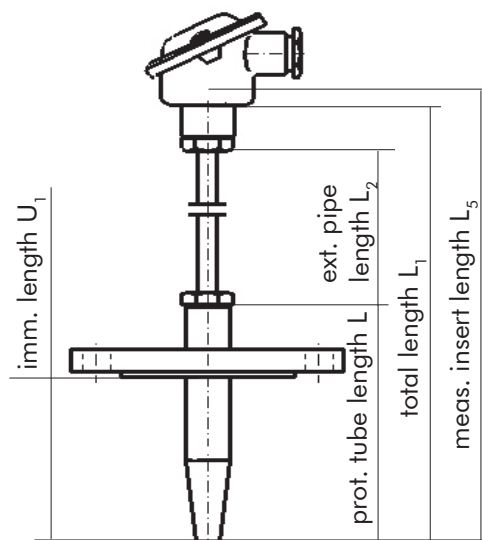

Fig. 9.2 – Thermocouple and resistance thermometer with protection tube form 4F

Table 9 Measuring insert length to protection tube length form 4 and 4F acc. to DIN 43 772

Protection tube form	Conn. head form B meas. insert length L_5 in mm	Prot. tube length L in mm	Immersion length U resp. U_1 in mm	Extension pipe length L_2 in mm	Total length L_1 in mm	Extension pipe thread N	Prot. tube outer diameter in mm	Inner diameter d_1 in mm
4	285 / Ø 6	110	65	140	275	M 18 x 1.5	$F_1 = 24\ h7$ $F_3 = 12.5$	7
	285 / Ø 6	110	73		275			
	315 / Ø 6	140	65		305			
	345 / Ø 6	170	133		335			
	375 / Ø 6	200	65		365			
	375 / Ø 6	200	125		365			
	435 / Ø 6	260	125		425			
	585 / Ø 6	410	275		575			
4F	375 / Ø 6	365	130	140	365	M 18 x 1.5	$F_1 = 24\ h7$ $F_3 = 12.5$	7
	435 / Ø 6	425	190		425			
	585 / Ø 6	575	340		575			
4	285 / Ø 3	110	65	140	105	M 14 x 1.5	$F_1 = 18\ h7$ $F_3 = 9$	3.5
	285 / Ø 3	110	73		105			
	315 / Ø 3	140	65		135			
	345 / Ø 3	170	133		165			
	375 / Ø 3	200	65		195			
	375 / Ø 3	200	125		195			
	435 / Ø 3	260	125		255			
	435 / Ø 3	260	125		255			
4F	375 / Ø 3	200	125	140	195	M 14 x 1.5	$F_1 = 18\ h7$ $F_3 = 9$	3.5
	435 / Ø 3	260	125		255			

Note: On request the protection tube forms 4 and 4F ($F_1 = 24\ h7$) are available also for measuring inserts with an outer dia. of 8.0 mm resp. code number 810.

Different measuring insert lengths and diameters are available on request, depending on the design of the protection tube.

In addition to the single, duplex and triplex designs profile thermocouples with different sensor lengths in a common protection tube are available.

10) Colour coding, thermal EMF and permitted deviations of thermocouples

Table 10 Color-coding of extension or compensating cable acc. to IEC 60 584-3:2008

Material	Fe-CuNi	Fe-CuNi	NiCr-Ni	Cu-CuNi	NiCr-CuNi	NiCrSi-NiSi	Pt10%Rh-Pt	Pt13%Rh-Pt	Pt30%Rh-Pt6%Rh
Ident. letter	L*	J	K	T	E	N	S	R	B
Color + Pole	---	black	green	brown	purple	pink	orange	orange	No color defined. In most cases grey (+) and white (-) are used as copper cable
	(red)	---	(red)	(red)	---	---	(red)	(red)	
Color - Pole	---	white	white	white	white	white	white	white	
	(blue)	---	(green)	(brown)	---	---	(white)	(white)	
Color sheath	---	black	green	brown	purple	pink	orange	orange	
	(blue)	---	(green)	(brown)	---	---	(white)	(white)	

Ident. letter acc. to EN 60 584 (DIN 43 710)

* Type L acc. to DIN 43 710 (standard withdrawn)

Colour code in brackets acc. to DIN 43 714

Table 11 Thermal EMF acc. to DIN EN 60 584-1 *)

Temperature °C	Type L **) μV	Type J μV	Type K μV	Type T μV	Type E μV	Type N μV	Type S μV	Type R μV	Type B μV
-200	-8150	-7890	-5891	-5603	-8825	-3990			
-100	-4750	-46330	-3554	-3379	-5237	2407			
0	0	0	0	0	0	0	0	0	0
100	5370	5269	4096	4972	6319	2774	646	647	33
200	10950	10779	8138	9288	13421	5913	1441	1469	178
300	16560	16327	12209	14862	21036	9341	2323	2401	431
400	22160	21848	16397	20872	28946	12974	3259	3408	787
500	27850	27393	20644		37005	16748	4233	4471	1242
600	33670	33102	24905		45093	20613	5239	5583	1792
700	39720	39132	29129		53112	24527	6275	6743	2431
800	46220	45494	33275		61017	28455	7345	7950	3154
900	53140	51877	37326		68787	32371	8449	9205	3957
1000		57954	41276		76373	36256	9587	10506	4834
1100		63792	45119			40087	10757	11850	5780
1200		69553	48838			43846	11951	13228	6786
1300			52410			47513	13159	14629	7848
1400							14373	16040	8956
1500							15582	17451	10099
1600							16777	18849	11263
1700							17947	20222	12433
1800									13591

**) Type L acc. to DIN 43 710 (standard withdrawn)

*) Cool-joint temperature at 0 °C

Table 12 Permitted deviations for thermocouples acc. to DIN EN 60 584-2

Permitted deviation	Class 1	Class 2	Class 3
Permitted deviation +/- *)	0.5 °C or 0.004 * (t) °C Range -40 ... + 350 °C	1.0 °C or 0.0075 * (t) °C Range -270 ... + 400 °C	
Permitted deviation +/- *) Range for type J **) Range for type K and N Range for type E	1.5 °C or 0.004 * (t) °C Range -40 ... + 750 °C Range -40 ... + 1000 °C Range -40 ... + 800 °C	2.5 °C or 0.0075 * (t) °C Range -40 ... + 750 °C Range -40 ... + 1200 °C Range -40 ... + 900 °C	4.0 °C or 0.005 * (t) °C Range -200 ... - 40 °C
Permitted deviation +/- *) Range for type S and R Range for type B	1.0 or (1+(t-1100)*0.003) °C 0 ... 1600 °C Not in standard	1.5 °C or 0.0025 * (t) °C Range 0 ... + 1600 °C Range + 600 ... + 1700 °C	

*) The higher value applies (t) = temperature in °C without algebraic sign **) Recommended operating temperature range

Type J, K, N and E: In the range of -200 to -40 °C class 3 should be used.

Thermocouple material of class 3 may not necessarily comply with class 1 or 2 at temperatures above -40 °C.

Thermocouple material of class 1 or 2 in most cases does not comply with class 3 at temperatures below -40 °C.

11) Permitted deviations for resistance thermometers

In DIN EN 60 751:2008 the correlation between temperature in °C and resistance in Ohm is defined for a platinum resistance thermometer with a resistance of 100 Ohms at 0 °C. The total temperature range extends from -200 °C to +850 °C. For technical reasons the limit deviations were re-defined in IEC 60 751 (German version DIN EN 60 751:2008). In particular a special distinction was made between flatform and wire-wound resistors on the one side and thermometers on the other side. In addition to resistance thermometers with 100 Ohms nominal resistance at 0 °C, resistors with 500, 1000, 5000 and 10000 Ohms are available.

Table 13 Permitted deviations for resistors acc. to DIN EN 60 751:2008

Wire-wound resistors		Flatform resistors		Tolerance value in °C
Tolerance class	Temperature range in °C	Tolerance class	Temperature range in °C	
W 0.1	-100 to 350	F 0.1	0 to 150	+/- (0.1+0.0017* t)
W 0.15	-100 to 450	F 0.15	-30 to 300	+/- (0.15+0.002* t)
W 0.3	-196 to 550	F 0.3	-50 to 500	+/- (0.3+0.005* t)
W 0.6	-196 to 660	F 0.6	-50 to 600	+/- (0.6+0.01* t)

|t| = absolute temperature value in °C independent of the algebraic sign

Table 14 Permitted deviations for thermometers acc. to DIN EN 60 751:2008

Tolerance class	Temperature range in °C		Tolerance value in °C
	containing wire-wound resistors	containing flatform resistors	
AA	-50 to 250	0 to 150	+/- (0.1+0.0017* t)
A	-100 to 450	-30 to 300	+/- (0.15+0.002* t)
B	-196 to 600	-50 to 500	+/- (0.3+0.005* t)
C	-196 to 600	-50 to 600	+/- (0.6+0.01* t)

|t| = absolute temperature value in °C independent of the algebraic sign

Graphical diagramm of the permitted deviations

The permitted deviation is symmetrical to the horizontal zero-line. Only the positive part is shown.

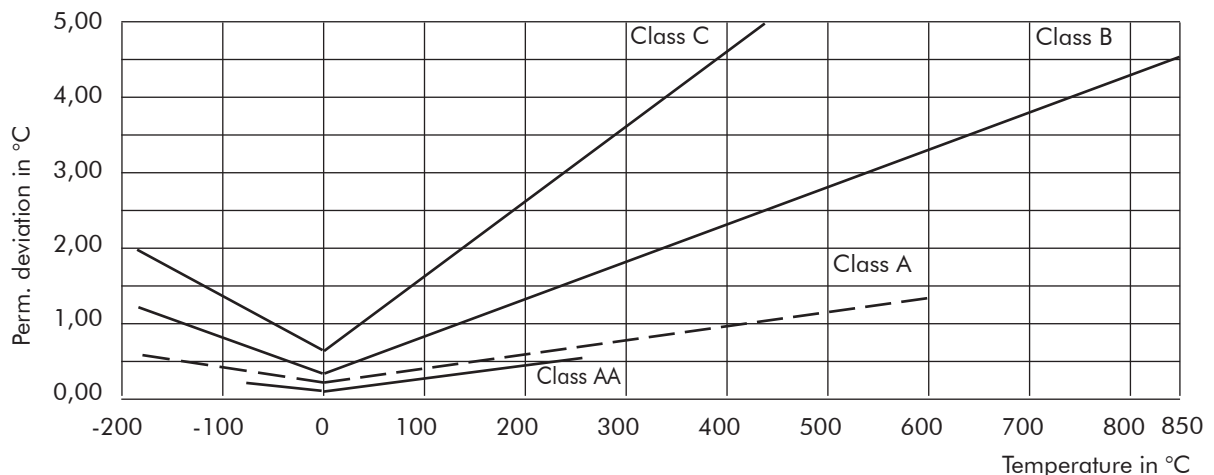

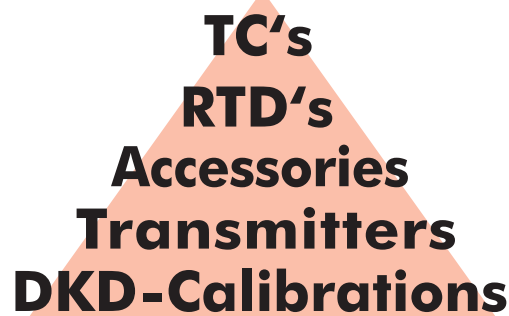

TC's
RTD's
Accessories
Transmitters
DKD-Calibrations

- ▲ High-temperature thermocouples up to 2300 °C
 - ▲ Profile and multipoint thermocouples
 - ▲ Special designs to customer specifications
 - ▲ MI thermocouples (ATEX)
 - ▲ Thermocouple measuring inserts (ATEX)
 - ▲ MI resistance thermometers (ATEX)
 - ▲ Resistance thermometer measuring inserts (ATEX)
 - ▲ Measuring resistors
-
- ▲ Calibration instruments and systems
 - ▲ Calibrators and simulators
 - ▲ Vendor certificates
 - ▲ Calibration laboratory DKD-K-09701 for temperature
www.centrocal.de and
<http://www.dkd.eu/laboratorien/en/kurzvvd.htm>
-
- ▲ Digital transmitters (EEx(i), HART)
 - ▲ Analog transmitters (EEx(i))
-
- ▲ Protection tubes acc. to DIN 43 772, ASME and special designs to customer specifications
 - ▲ Connection heads form A and B acc. to EN 50 446
 - ▲ Ceramic connection sockets
 - ▲ Connection cables acc. to DIN 43 722 (DIN 43 714), IEC 60 584-3 and special designs

The right to modifications, which serve technical progress, is reserved.

RÖSSEL-Messtechnik GmbH

Lohstraße 2
59368 Werne/GERMANY
Fon: +49 (0) 2389 409-0
Fax: +49 (0) 2389 409-80
Mail: info@roesselwerne.de
Web: www.roesselwerne.de

RÖSSEL-Messtechnik GmbH

Spenerstraße 1
01309 Dresden/GERMANY
Fon: +49 (0) 351 31225-0
Fax: +49 (0) 351 31225-25
Mail: info@roesseldresden.de
Web: www.roesseldresden.de

RÖSSEL

Eikenlaan 253d
2404BP Alphen a/d Rijn
THE NETHERLANDS
Fon: +31 (0) 172 493141
Fax: +31 (0) 172 495043
Mail: info@rossel.nl/Web: www.rossel.nl